

National Forum to Connect and Advance Library Makerspaces

Concluding Webinar
January 23, 2026



LG-256680-OLS-24

CU COMMUNITY
FAB *Lab*



UNIVERSITY OF
ILLINOIS CHICAGO

College of Education

**LIBRARY
MAKERS**



**NATION OF
MAKERS**



National Maker
COLLECTIVE

ALA
American
Library
Association

Agenda



Introduction



Project overview and findings



Panel discussion



Open discussion and Q&A

NATIONAL LIBRARY MAKERSPACES FORUM

TEAM



Dr. Kyungwon Koh
(she/her)

Project Director

Associate Professor
Director, The Champaign-Urbana
Community Fab Lab
School of Information Sciences
The University of Illinois at Urbana-
Champaign



Dr. Rebecca Teasdale
(she/her)

Project Co-Director

Associate Professor
Educational Psychology
University of Illinois Chicago



Emilie N. Butt, MSLIS
(she/her)

Project Coordinator

Instruction and Engagement Coordinator
The Champaign-Urbana Community Fab Lab
Informatics, School of Information Sciences
The University of Illinois Urbana-Champaign



TEAM MEMBERS



**Leanne Nay, MLS
(she/her)**

- Creative Technologies Librarian, Indiana University Libraries
- Past chair of the ALA Core Maker Technology Interest Group



**Sarah Nagle, MSLIS
(she/her)**

- Creation and Innovation Services Librarian, Miami University Libraries
- Chair of the ALA Core Maker Technology Interest Group; Formal co-chair of the Nation of Makers Libraries Working Group; Co-founder of the National Maker Collective



**Dr. Lisa Regalla,
(she/her)**

- CEO, Regallium Consulting
- Project Co-Director, Library Makers



**Cara Kouse, MLIS,
(she/her)**

- Innovation and Makerspace Manager Greene County Public Library
- Co-chair of the Nation of Makers Libraries Working Group; Co-founder of the National Maker Collective

Project Overview

- Convened library professionals, educators, researchers, and students
- Explored evolution, future, and sustainability of library makerspaces
- Focus: strategic planning, networking and knowledge sharing, and generating new ideas for thriving makerspaces



Project Goals

1. Strengthen coordination and collaboration among maker groups
2. Synthesize and leverage existing knowledge in library makerspaces
3. Identify future directions, resources, and opportunities



Project Activities and Results

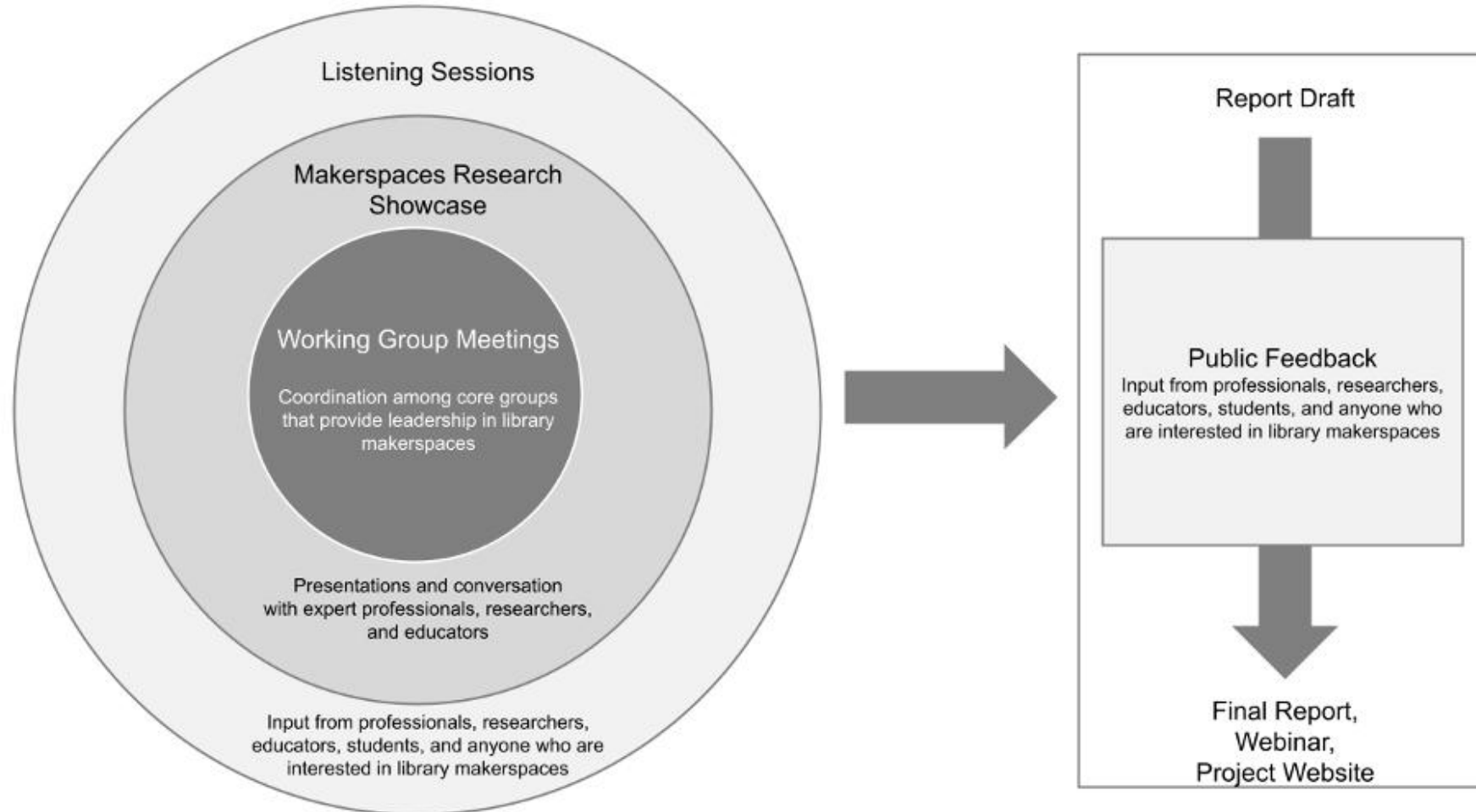

Intended Outcomes



Articulate their mission and vision to administrators, users, fellow librarians, and broader stakeholders.



Inform and strengthen their strategic planning and decision-making processes.



Advocate for their work and priorities by presenting a clear, evidence-based framework to administrators and decision-makers.



Strategic Directions for Library Makerspaces

Values, Vision, Priorities, and Resources



Strategic Directions for Library Makerspaces

Reflect the grassroots perspectives of professionals in public, school, and university library makerspaces across the US

- Gathered input through 3 listening sessions in March 2025 plus asynchronous feedback
 - Open to all who wished to collaboratively envision and plan the future
- 

Interconnected Aspects

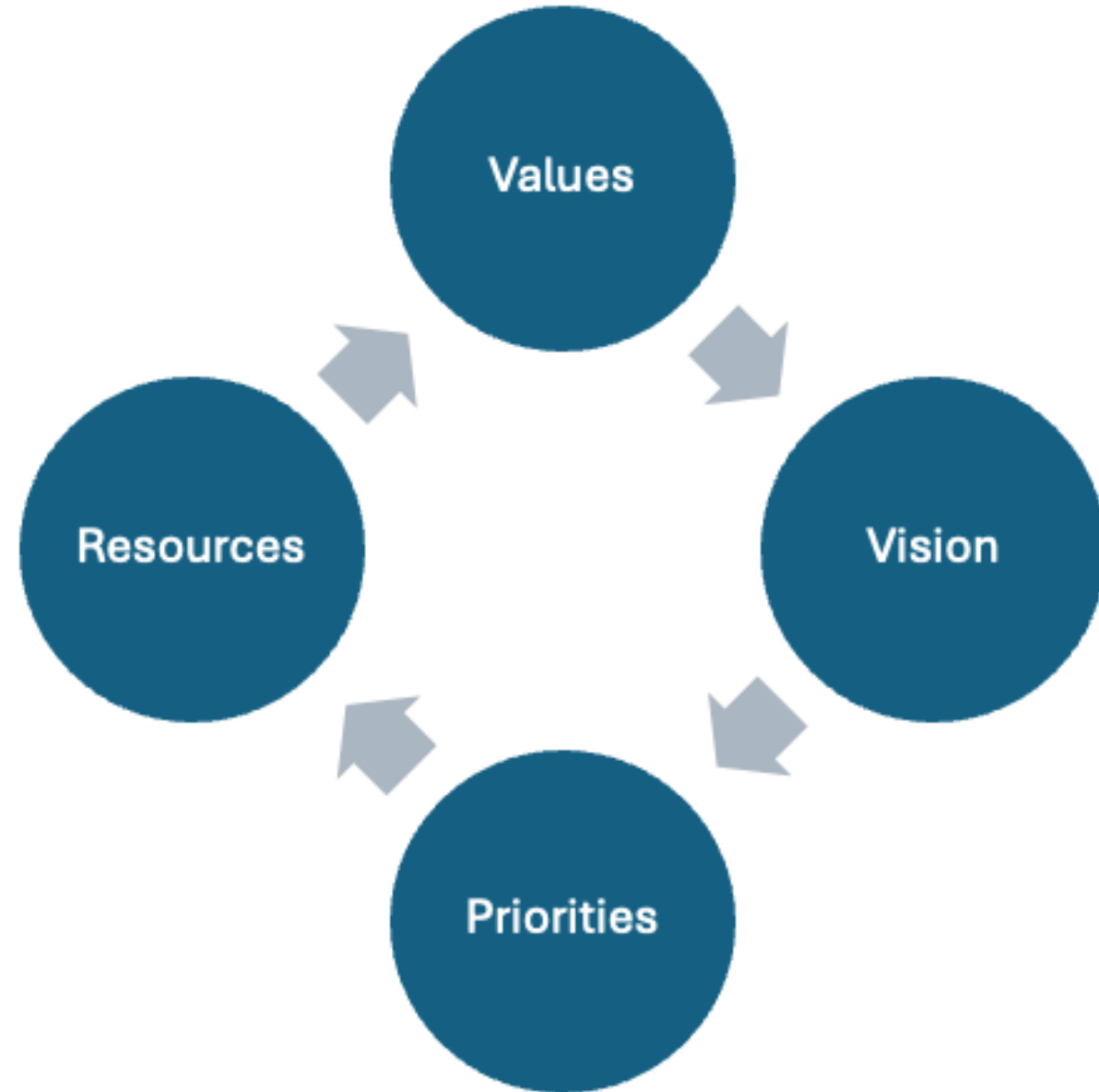

The Five Core Values

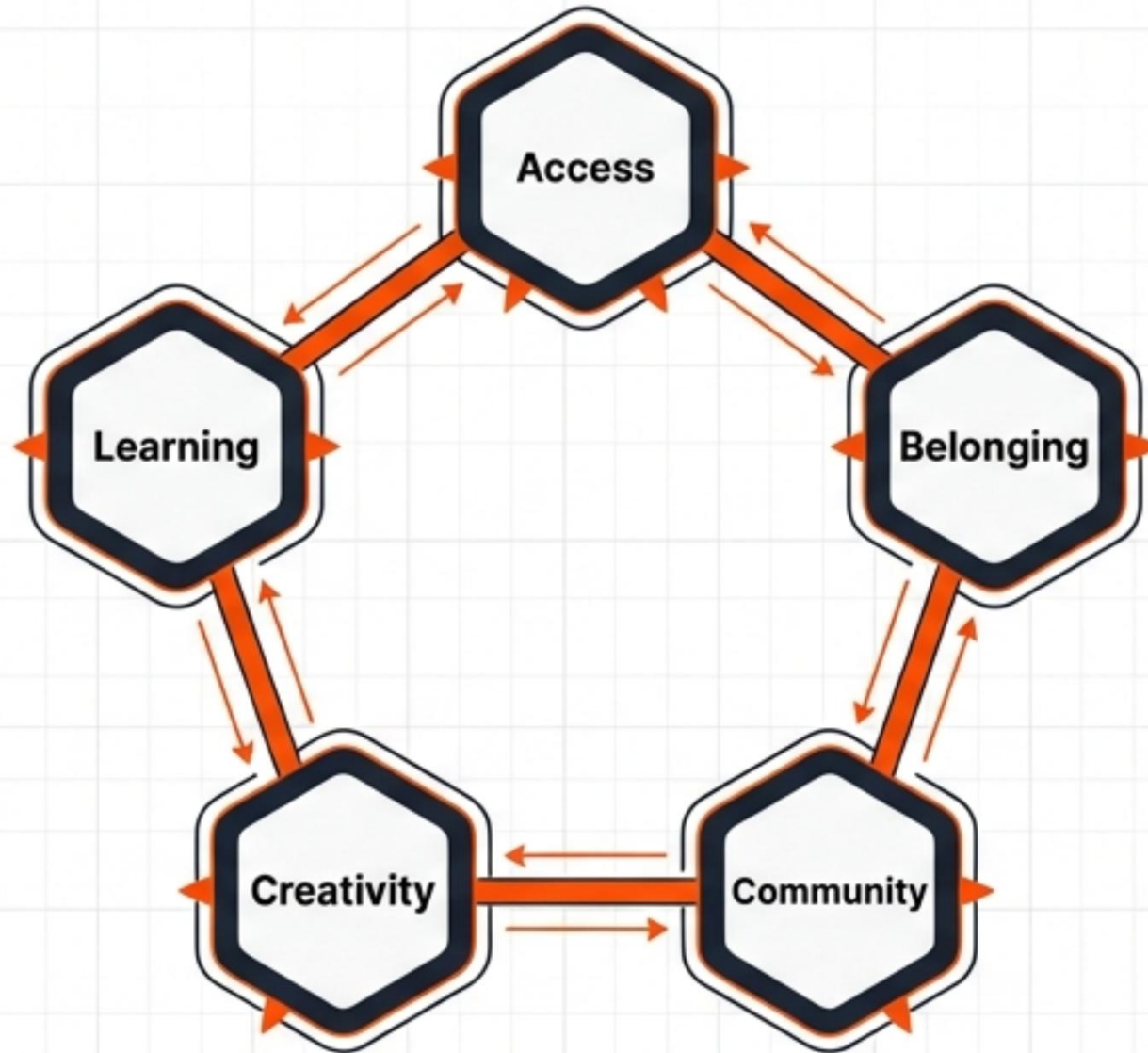

Vision: Makerspaces

Vibrant, well-utilized spaces

Range of users across ages, experiences, identities, and backgrounds

Accessible, welcoming, respectful, and supportive environments

Seamlessly integrated into parent organizations

Widely recognized and valued by the community



Vision: Individual Makers

Expanded knowledge, skills, and literacies

Increased confidence and joy

Success in creative, academic, and entrepreneurial pursuits



Vision: Community & Society

More connected communities

Greater sustainability through practices like repair, reuse, and waste reduction

More equitable access to tools, resources, technologies, and opportunities



Priorities



Sustainable infrastructure:
Building stronger and scalable foundations



Community engagement and partnerships:
Deepening connections and building strategic partnerships



Staff development:
Investing in people



Advocacy and communication:
Strengthening internal and external voices



Adaptability and innovation: Meeting evolving needs while bridging technology gaps

Resources



Adequate & sustained funding



Appropriate staffing & protected staff time



Resources for professional development and training



Structures for knowledge sharing and networking



Organization & community buy-in





Strategic Recommendations

Insights from the Field

The Current Reality: The Strengths

- Extend libraries' mission through hands-on, community-centered learning
- Maker groups and networks
- Research bridges scholarship and practice with diverse, creative approaches

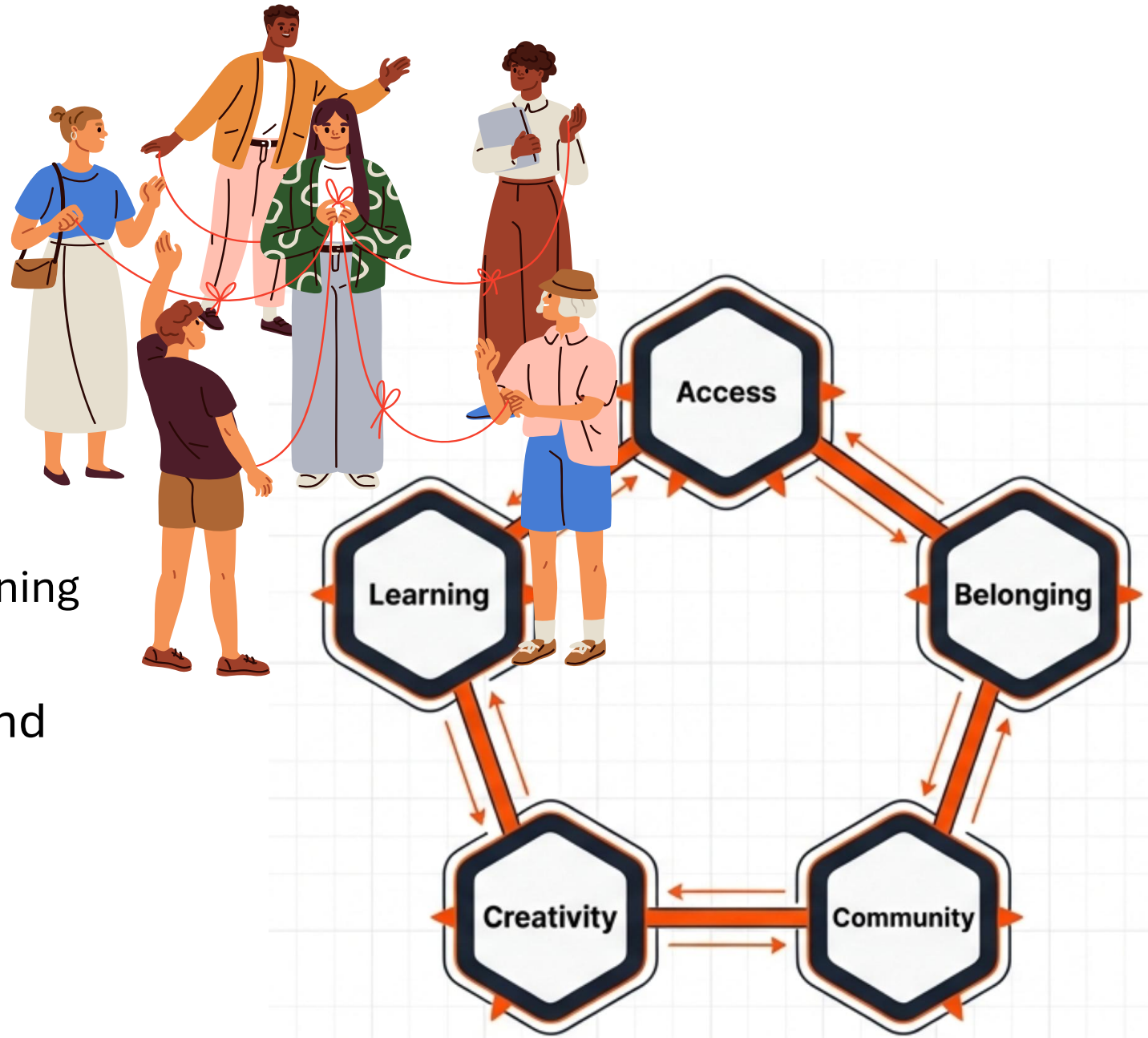

The Current Reality: The Challenges

- **Perception:** Often seen as "niche" or "peripheral."
- **Fragility:** Unstable funding and reliance on individual champions.
- **Data Gap:** Lack of national census data makes advocacy difficult.
- **Equity:** Inclusion remains aspirational in many contexts; physical/social barriers persist.

Moving from Novelty to Essential Core Service



The Problem

While passion is high, infrastructure is often fragile. We must move beyond the initial “hype” to chart a path for long-term sustainability and integration.

Recommendations 1.

Strengthen the Foundation:
Organizational and Field-Wide
Sustainability

Actionable Steps:

- **Robust physical and digital infrastructure:** from equipment to well-designed spaces to digital management tools (scheduling, evaluation tracking, etc.)
- **Clear operational systems:** Shared systems + local development
- **Diversified funding models:** Institutional support, grant, partnerships, and other revenue sources

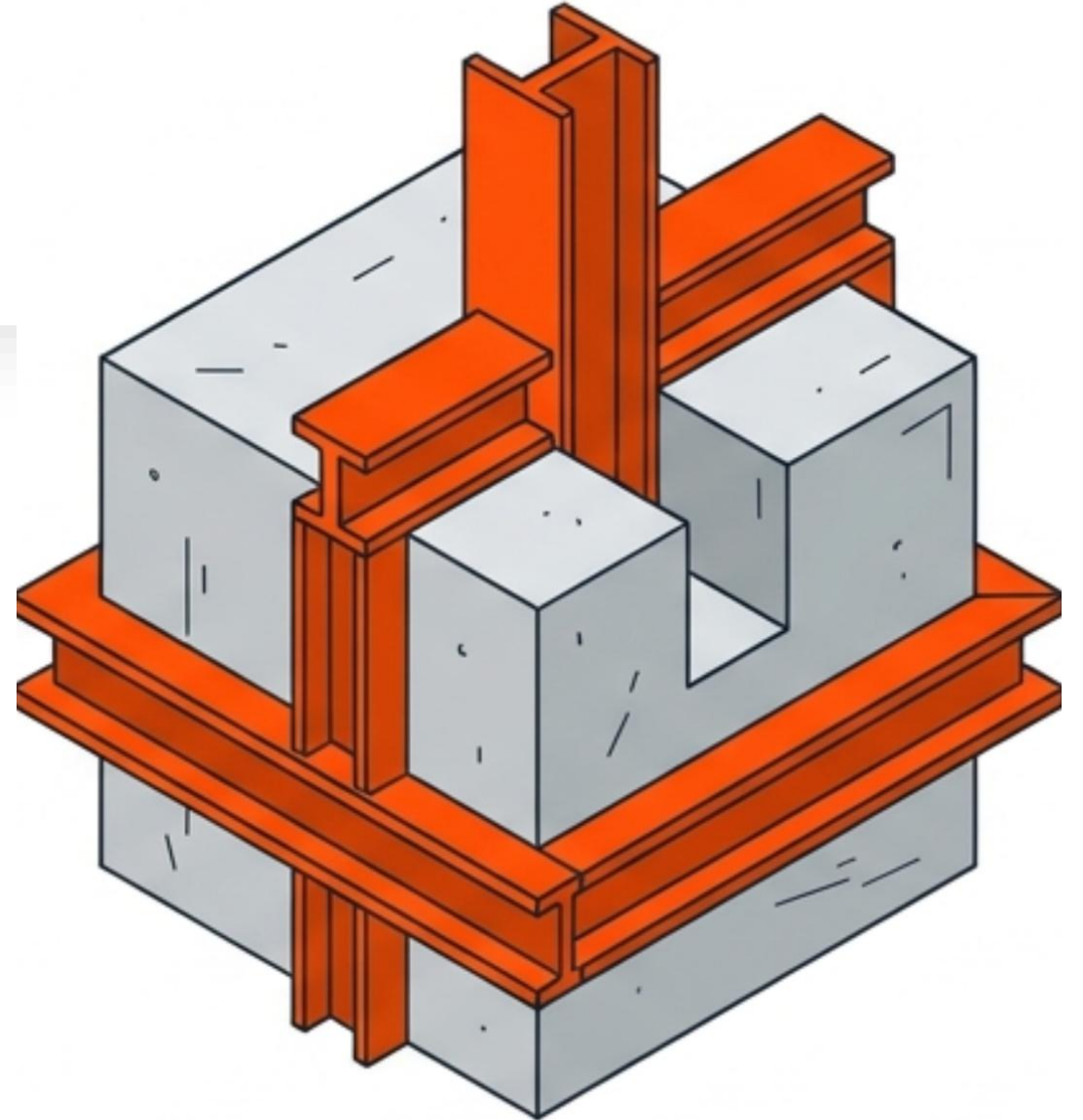

Recommendation 2. Grow the People: Learning and Leadership Development

Actionable Steps

- **Formalize Education:** Integrate maker coursework into Library and Information Science (LIS) degrees and certificate programs
- **Mentorship:** Structure programs connecting students, new professionals, and experts
- **Equitable access:** Ensure professional development reaches rural and under-resourced library workers



Key Insights: Create staff development pipelines and training systems



Recommendation 3. Connect the network: Partnerships & Collaboration

Actionable Steps:

- **Digital Infrastructure:** Maintain shared repositories for tutorials, toolkits, and best practices
- **Regular Dialogue:** Sustain forums for exchange between practitioners and researchers
- **Cross-Sector Partnerships:** Collaborate across research, practice, and communities

Key Insight: Move from isolated innovation to collective progress.



4. Elevate the Message: Advocacy Grounded in Clear Strategic Identity

Actionable Steps:

- **Clarify Definitions:** Use terms that resonate (e.g., creative space, learning space) based on stakeholder values
- **Reframe the Narrative:** Center stories on values, rather than just tools.
- **Data-Backed Storytelling:** Collect data and impact metrics to substantiate the anecdotes

Key Insight: "Shout it from the rooftops"—but ensure the message aligns with the library's core mission.



5. Look Ahead: Innovation and Emerging Issue

Actionable Steps

- **Emerging Tech:** Create space to experiment with new tech and digital/physical intersections
- **Environmental Sustainability:** Lead by modeling repair, reuse, and upcycling initiatives
- **The Digital Divide:** Remember that for many, “adaptability” still means bridging basic technology literacy gaps

Key insight: Balance the cutting edge with the barrier to entry



Panel Discussion

Facilitator: Dr. Kyungwon Koh

Panelists: Leanne Nay, Sarah Nagle,

Dr. Lisa Regalla, and Cara Kouse

Panel Discussion



Which of the Forum’s shared strategic directions feels *most urgent* or *promising* to you right now, and why?



How has your group built on the Forum’s findings? Can you share an example of work that grew directly from them?



How might libraries—large or small, well-resourced or not—put these findings into practice? What’s one realistic step a library could take this year to support or grow its makerspace?



Open Discussion and Q&A

Facilitator: Dr. Rebecca Teasdale

Discussion



Takeaways: What stood out to you from the findings or panel reflections? What feels most relevant for your work?

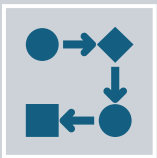

Next Steps: How might you use these findings to support and advance your makerspace? What would you like to see happen next?

Thank you!

Visit our website and subscribe for update.

<https://publish.illinois.edu/librarymakerspaces/>

