

---

## 27 ***EXPLORING THE ROLE OF ANCIENT MAYA TEMPLES AT YALBAC, BELIZE***

*Lisa J. Lucero*

---

*Throughout the world, places of worship –temples or churches– are built to honor various gods, patron deities, or as places for religious expression and experiences. Scholars’ interpretations of Late Classic (c. A.D. 550 – 850) Maya temples have been relatively vague on their roles and functions except in cases where they served as stages for royal ceremonies. Since the majority of secondary centers such as Yalbac, do not have written or obvious iconographic records, I explore the possibility of temple attributes revealing histories given their crucial role in daily social, religious, and political life. The analysis of evidence from looters trenches at Yalbac, while preliminary, has exciting implications regarding the role of temples and their potential to serve as text on Classic Maya society.*

### **Introduction**

Throughout the world, places of worship –temples or churches– are built to honor various gods, patron deities, or as places for religious expression and experiences. Temples are also major landmarks and create the need for labor, as in Egypt, Mesopotamia, and South India (e.g., Morrison 1993). Temples link towns and their rural hinterlands through periodic ceremonies, festivals and feasts, and “represent an impressive commitment of resources to ... faith” (Stein 1977:25) as witnessed in their maintenance, ritual specialists, and support staff. Inscriptions and iconography note to whom the temple was dedicated as well as who constructed it, they highlight the kinds of donations including land and village revenues. Temples also serve as the core of royal public life because religion is vital for political legitimating - monarchs fund temples and conduct most of their ceremonies at temples. Rites revolve around royals and their ancestors to show that they have the ‘mandate of heaven’ (e.g., Chang 1983) because worldwide rulers are associated with prosperity (Hocart 1970[1936]: 128-155). In Egypt, for

example, everyone relied on the pharaoh to perform key rites to ensure that the Nile would bring adequate water (Hassan 1994). The king was the major intermediary between heaven and earth. In brief, cross-culturally temples provide sanctuary, a home for gods, a place to worship and pray a stage for religious and political ceremonies, festivals and feasts, storage for food and supplies, workshops for the manufacture of sacred and profane goods, a depository for offerings, and a place to redistribute food and gifts.

Scholars’ interpretations of Late Classic (A.D. 550-850) Maya temples have, however been relatively silent on these matters (cf. Loten 2003; Taube 1998). While well described, discussion of temples rarely focuses on more than the basic function of serving as stages for elites and kings to perform religious ceremonies. This is somewhat surprising since Maya centers are famous for their temples, which are inscribed or decorated with vibrant scenes, focusing on the builders of temples - kings, their families, and their ancestors. Gods played a secondary role. The history or function of the temple, however, is not revealed by this monarch-centric focus.

Were all Maya temples built the same, or do temples show variability? In either case, did they serve varied functions? Were temples built for different gods, or did they all have similar functions? Were they funded by different groups of people, not just kings? Different groups could include wealthy families or elites, lesser royals or nobles, or even community members. The fundamental question is: Why did the Maya build so many temples? Before we can address these questions, we need more concrete information about temple histories. In this paper, I present preliminary data from temple looters trenches at Yalbac that show promising results regarding variability.

Since the majority of secondary centers like Yalbac do not have written records, I explore whether or not temple attributes can reveal histories indicating that temples were crucial in daily social, religious, and political life. Attributes explored include frequency of temples within centers, size differences, location with regard to other monumental architecture, layout and accessibility (private or restricted), history of use, and construction patterns including style, labor, materials, decorative features, and ritual deposits.

### **Yalbac**

Yalbac site is located under jungle canopy, near pockets of good agricultural land, along Yalbac Creek, a perennial stream, on the eastern border of the southern lowlands (Graebner 2002a, 2002b; Lucero 2004; Lucero et al. 2004). J. Eric Thompson made brief mention of an eastern group of Yalbac in the 1930's (1939:2, 282), but appeared to have inadvertently missed the site core (Figure 1). Plaza test pits yielded ceramics dating from c. 300 B.C. through A.D. 900, or the Late Preclassic through the Terminal Classic period.

The six pyramid temples at Yalbac range from 8 to 16m in height of which five

exhibited looters trenches (LTs). The looters trenches were recorded in profiles during the 2002-2004 seasons and yielded important clues as to construction sequences. At present, the temples all appear to lack summit structures and plaster floors; some have cut-stone terraced facades and dry and mortared boulder and cobble core fill. Surface ceramics indicate the temples were used through the Late Classic period (A.D. 550-850), even though the Maya began building some much earlier in the Late Preclassic (300-100 B.C.) (e.g. Plaza 3 temples).

All temples are located on large open plazas, though Plaza 3 is slightly more restricted than Plaza 2. These two plazas contain the two tallest temples, Str. 2A (40 x 36 m, 16 m tall) and Str. 3A (45 x 25 m, 11 m tall), and Plaza 2 has the only ballcourt. Interestingly, the western structure of the ballcourt is attached to the front of the temple rather than at the back as one finds at Xunantunich and Cahal Pech; either the Maya no longer used the temple or moved the staircase to the side, or they built the temple after the ballcourt, perhaps to enclose the plaza (John Morris, pers. comm., 2004). Str. 3A and Str. 3D (45 x 25, 8 m tall) are the only temples with wings on the north and south sides, which likely contain tombs (Jaime Awe, pers. comm. 2004).

Plaza 2 temples are on average bigger than Plaza 3 temples (15,960 cm<sup>3</sup> vs. 7,792 cm<sup>3</sup>). Plaza 2 temples have more faced stones on average (19% vs. 12%) and are thrice the average size of the Plaza 3 temples (1,318 cm<sup>2</sup> vs. 435 cm<sup>2</sup>). Shaped stone blocks are faced on all exposed sides, especially on the front sides of temples. The back or sidewall blocks appear to be faced only on one side (e.g. LT 7 and LT 29, Str. 3A). The exposed core fills at Str. 2E (40 x 36 m, 8 m tall) and Str. 2F (30 x 30 m, 10 m tall) have mortar, usually of marl, plaster, gravel, or sand. In contrast, Str. 3A and Str.

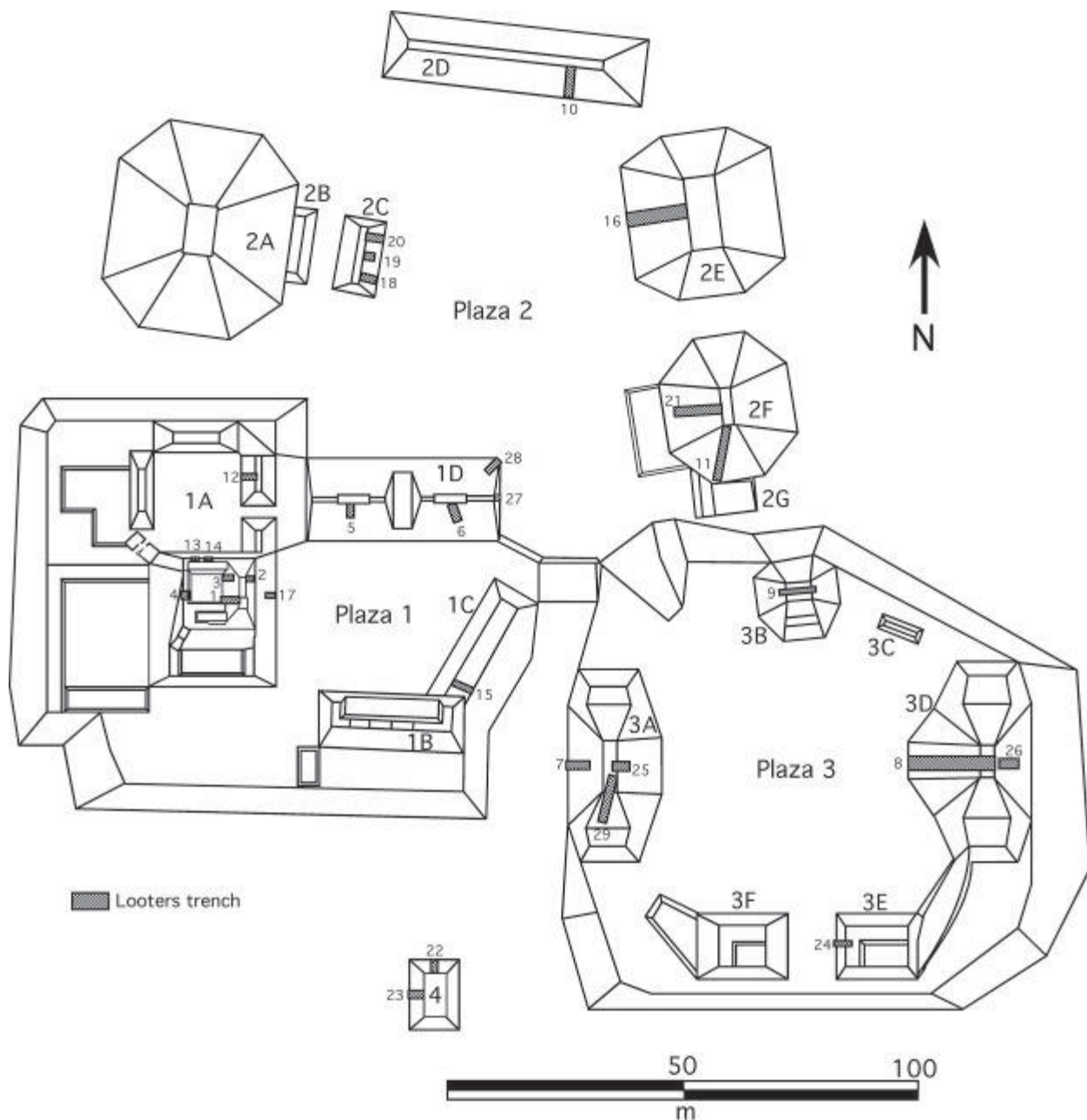

Figure 1. Yalbac.

3B (20 x 20 m, 6 m tall) have both mortared and dry core fills; while dry core fill requires less materials and labor, it is more difficult to contain and is more unstable (Schele and Mathews 1998:30). Core fill boulders are larger on average in Plaza 2 temples, averaging 569 cm<sup>2</sup> compared with 416 cm<sup>2</sup> at Plaza 3 temples, and they comprise a greater proportion (30% vs. 15%).

However, Plaza 3 temples have more similarly sized (sorted) faced stone and core fills (boulders, small boulders, and cobbles); for example, the average range difference of Plaza 3 faced stone is 564 cm<sup>2</sup> compared with 1887 cm<sup>2</sup> at Plaza 2 temples. The Maya may have used more midden deposits since we found greater quantities of sherds in Plaza 3 temples (though they might

represent items broken by looters). In sum, the Maya built bigger Plaza 2 temples using larger stone blocks and mortared fills, and used more sorted fills for Plaza 3 temples.

In a preliminary comparison with contemporary construction patterns of three residential compounds within 500 m of the site core, it is clear that the Maya used larger faced stones and boulders (length is greater than 15 cm) at temples. Small boulders (length: between 11-15 cm) and cobbles (length: 1-10 cm) are more comparable in size. For example, the eastern mound (23 x 9 m, 2.5 m tall) of Site 4, an elite compound consisting of seven structures around a plaza, has standing walls constructed with faced stone blocks. They range from 50 to 362 cm<sup>2</sup>, whereas those from temple LTs range from 251 to 1678 cm<sup>2</sup>. The range decreases as site size diminishes; Site 14, a U-shaped elite structure (28.5 x 18 m, 3 m tall) (Graebner and Lucero 2003), has standing walls with faced stones ranging from 40 to 350 cm<sup>2</sup> and Site 18, a commoner house (9.5 x 9.5 m, 1.5 m tall) (Lucero and Graebner 2003), has low walls with faced stones ranging from 38 to 294 cm<sup>2</sup>.

Temple LTs have also revealed that construction patterns differ from acropolis type construction patterns, (Str. 1A, 55 x 45 m, 20 m tall) (Hooper 2004a, 2004b), the surface ceramics of which date to the Late Classic. The upper most acropolis LTs (1 and 2) exposed vaulted ceilings, a possible roof comb, red-plastered walls, a molded and plastered throne bench, thick walls (0.7-1 m), and standardized cut limestone (Figure 2). When the Maya filled in these rooms before rebuilding, they used sorted fill and a compact plaster mortar. Plaster floors are thick (5 cm+) and of high quality (fine, hard). Plaster has relatively high labor costs (Abrams 1998). From LT 4 on the upper west terrace of the royal residence, we recovered architectural decoration from the looter's back dirt consisting of stucco

fragments with traces of red paint. The LT on at the base of Str. 1A on Plaza 1, LT 17, exposed construction styles more similar to LTs at the temples (boulder core fill, faced stone façade, and no obvious plaster floors), as well as a speleothem fragment, (considered sacred to the Maya as portals to the Xibalba).



Figure 2. Acropolis architectural features.

We do not know much about ritual deposits because looters apparently were quite successful in removing caches and grave goods. However, since looters were not interested in broken items and left them behind, we do have some idea; for example, LT 9 at Str. 3B revealed a Late Classic burial immediately underneath the eastern summit stone facade, most of which was destroyed by looters (Figure 3). The remaining lip-to-lip vessels contained drilled shell, obsidian points, and a cut and polished jaguar tooth. From a lithic concentration at the roots of an uprooted tree, (likely from over a tomb) at the northeast side of Str. 3D, we recovered thousands of thin fine-grained pastel-colored chert blades and flakes. The Maya were known to place thousands of chipped chert or obsidian flakes and blades over the lintel or roof of a tomb, in caches, such as those found at Tikal (Moholy-Nagy 1997). During the clean-up of LT 8, Str. 3D, we also recovered human skull fragments, a complete unmodified clam



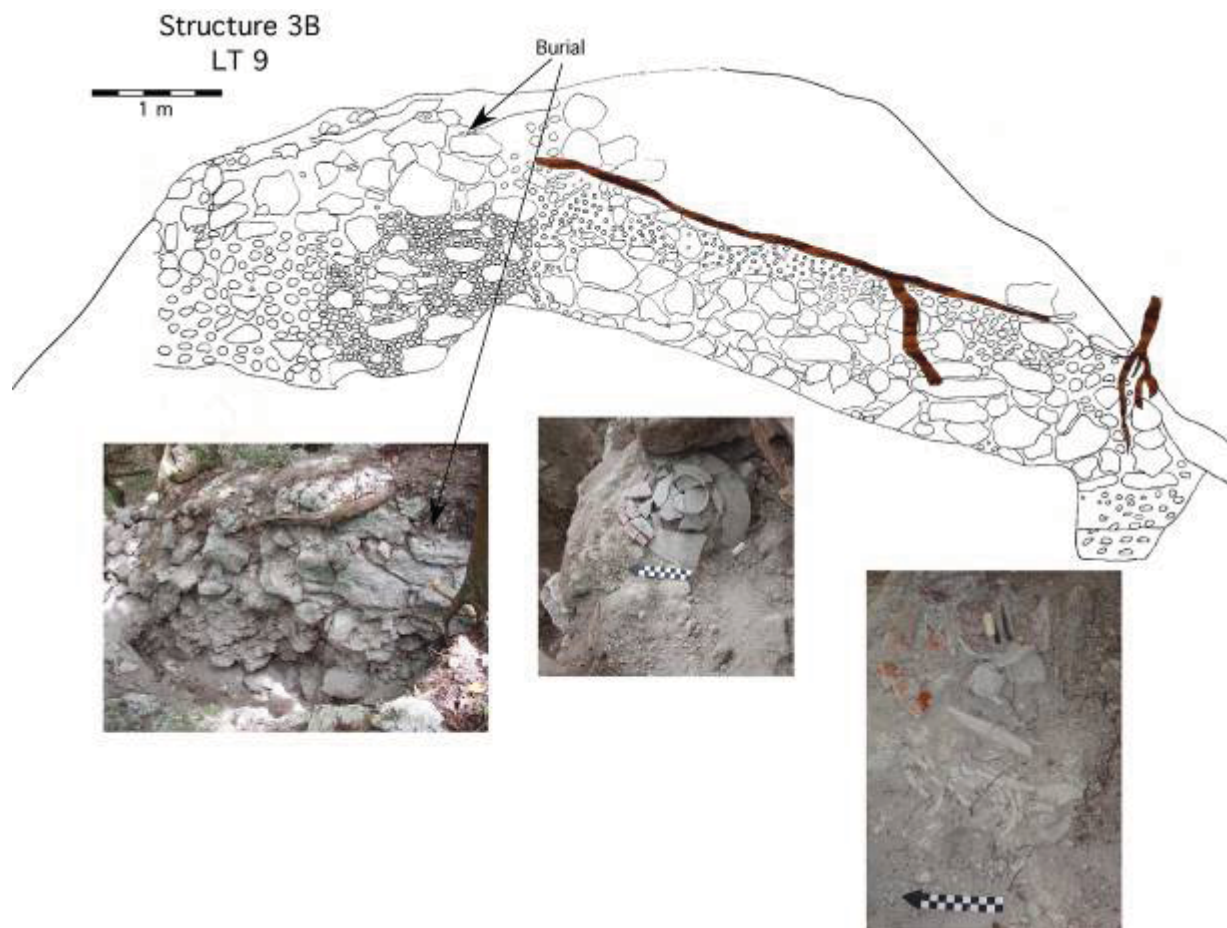

**Figure 3.** Structure 3B, LT 9 burial.

shell, a slate disc (likely a mirror backing), obsidian blades, a marine shell disc, and many decorated sherds from vases, jars, plates, and bowls. During the clean up of LT 21, Str. 2F, we found a figurine fragment of a head, perhaps of God N (Figure 4). While the exact significance of this deity is not totally agreed upon, God N is definitely associated with the celestial world as, for example, a sky-bearer, and is also associated with sacred mountains (Taube 1992:92-99). God N is often depicted with *Chaak*, the rain god, another celestial connection. Finally, the ballcourt alley test excavations yielded several speleothem fragments.

The architectural differences among temples and between other structure types are obvious and may indicate to whom they

are dedicated and by whom they were built. To address these issues, we plan in future seasons to collect more information on temple histories, architectural features including terraces, staircases and plastered surfaces and decorative features including masks, inscribed or painted walls, doorways, or lintels, as well as stelae or altars. We also intend to investigate labor expenditure which would be needed for each Late Classic building phase (e.g., river or quarried cobbles, the percentage of plaster in mortared fills, and the type of limestone used), and the location, quantity, quality and diversity of ritual deposits,

### **Concluding Remarks**

Did Str. 2F serve as a rain/celestial



Figure 4. Figurine fragment from Structure 2F, perhaps of God N.

temple (God N)? It is attached to Str. 2G, which on closer inspection might turn out to be an artificial pool (it is quite steep on all sides). What is the significance of the ballcourt being attached at the front of the largest temple (Str. 2A)? Were the ballcourt and temple a stage for re-enacting creation rites, since ballcourts play a large role in origin myths (Schele and Miller 1986:243-245)? Its proximity to the acropolis might indicate its association with the ruling family. Further, its location on the largest and most accessible plaza indicates large audiences. Plaza 3 temples might represent a necropolis, perhaps for founding and royal families; the large plaza size suggests that public ceremonies took place, whatever their purpose.

Architectural and ritual data are critical when centers lack obvious iconographic and hieroglyphic records. Even when the records are present, they

focus on kings, not gods. Does this mean that temples without inscriptions were built by non-royals, or were they all built by the royal family and thus did not require kings to claim the obvious? If all temples were similarly built, does this indicate that they served multiple functions—for example, seasonal ceremonies, feasts, games, royal rites, and other public events? If temples show variability, does it indicate that they were built by different groups (e.g., factions) or that they were built for different gods or functions? Do differences only indicate their being built at different times in the Late Classic (cf. Jones 1996, 2003)? These questions are critical, especially since most secondary centers such as Yalbac lack inscriptions and/or public iconography. The results presented, while preliminary, have exciting implications regarding the role of temples and their potential to serve as text on Classic Maya society.

*Acknowledgments.* I want to thank the Institute of Archaeology for their continued support, especially Jaime Awe and John Morris. I also want to thank the organizers of the conference, especially Sherilyne Jones. Continued support from Robert Vitolo is invaluable, as is that from New Mexico State University and field school students Sandra Andrade, Joanne Baron, Adam Lujan, Ivy Luchetti, and Chad Norred. None of the fieldwork would have been possible without the support and friendship of field assistants Zedikiah Scott, Clefo Choc, Jose Ernesto Vasquez, Isabel Ascencio (Don Luna), and Henry de Paz. Finally, I want to thank Nadine Gray for taking time out from her dissertation research to conduct the chronological assessment of the ceramic assemblages.

## References Cited

- Abrams, Elliot M.  
1998 Sites as Structures: The Construction Process and Maya Architecture. In *Function and Meaning in Classic Maya Architecture*, edited by S. D. Houston, pp. 123-140. Dumbarton Oaks, Washington, D. C.
- Chang, K. C.  
1983 *Art, Myth, and Ritual: The Path to Political Authority in Ancient China*. Harvard University Press, Cambridge.
- Graebner, Sean M.  
2002a Monumental Architecture and the Ancient Maya: The Royal Acropolis at Yalbac, Central Belize. M.A. Thesis. New Mexico State University, Las Cruces.  
2002b Ancient Maya Royal Courts: Yalbac, Central Belize. In *Results of the 2001 Valley of Peace Archaeology Project: Saturday Creek and Yalbac*, edited by L. J. Lucero, pp. 73-83. Report submitted to the Department of Archaeology, Ministry of Tourism and Culture, Belize.
- Graebner, Sean M., and Lisa J. Lucero  
2003 Residential Yalbac: Site 94N22N-14. In *Results of the 2002 Valley of Peace Archaeology Project: Yalbac*, edited by L. J. Lucero, pp. 18-41. Report submitted to the Department of Archaeology, Ministry of Tourism and Culture, Belize.
- Hassan, Fekri  
1994 Population Ecology and Civilization in Ancient Egypt. In *Historical Ecology: Cultural Knowledge and Changing Landscapes*, edited by C. L. Crumley, pp. 155-181. School of American Research Press, Santa Fe.
- Hocart, Arthur M.  
1970 [1936] *Kings and Councillors: An Essay in the Comparative Anatomy of Human Society*. Edited by R. Needham. University of Chicago Press, Chicago.
- Hooper, John M. D.  
2004a Energetic Investment in the Acropolis at Yalbac, Belize: A Comparative Approach. M.A. Thesis. New Mexico State University, Las Cruces.  
2004b Yalbac's Royal Acropolis: Looter's Trench Operations. In *Results of the 2003 Valley of Peace Archaeology Project: Yalbac*, edited by L. J. Lucero, pp. 13-35. Report submitted to the Institute of Archaeology, National Institute of Culture and History, Belize.
- Jones, Christopher  
1996 *Excavations in the East Plaza of Tikal*. Tikal Reports No. 16. University Museum Publications. University of Pennsylvania, Philadelphia.  
2003 The Tikal Renaissance and the East Plaza Ball Court. In *Tikal: Dynasties, Foreigners, and Affairs of State*, edited by J. A. Sabloff, pp. 207-225. School of American Research, Santa Fe.
- Loten, H. Stanley  
2003 The North Acropolis: Monumentality, Function, and Architectural Development. In *Tikal: Dynasties, Foreigners, and Affairs of State*, edited by J. A. Sabloff, pp. 227-252. School of American Research, Santa Fe.
- Lucero, Lisa J.  
2004 Exploring Classic Maya Politics: Yalbac, Central Belize. In *Archaeological*

- Investigations in the Eastern Maya Lowlands: Papers of the 2003 Belize Archaeology Symposium*, edited by J. Awe, J. Morris, and S. Jones, pp. 83-91. Research Reports in Belizean Archaeology Volume 1. Institute of Archaeology, National Institute of Culture and History, Belmopan, Belize.
- Lucero, Lisa J., Scott L. Fedick, Andrew Kinkella, and Sean M. Graebner  
2004 Ancient Maya Settlement in the Valley of Peace Area, Belize. In *Archaeology of the Upper Belize River Valley: Half a Century of Maya Research*, edited by J. F. Garber, pp. 86-102. University Press of Florida, Gainesville.
- Lucero, Lisa J., and Sean M. Graebner  
2003 Residential Yalbac: Site 94N22N-18. In *Results of the 2002 Valley of Peace Archaeology Project: Yalbac*, edited by L. J. Lucero, pp. 42-50. Report submitted to the Department of Archaeology, Ministry of Tourism and Culture, Belize.
- Moholy-Nagy, Hattula  
1997 Middens, Construction Fill, and Offerings: Evidence for the Organization of Classic Period Craft Production at Tikal, Guatemala. *Journal of Field Archaeology* 24:293-313.
- Morrison, Kathleen D.  
1993 Supplying the City: The Role of Reservoirs in an Indian Urban Landscape. *Asian Perspectives* 32:133-151.
- Schele, Linda, and Mary Ellen Miller  
1986 *The Blood of Kings: Dynasty and Ritual in Maya Art*. George Braziller, New York.
- Stein, Burton  
1977 Temples in Tamil Country, 1300-1750 A.D. *Indian Economic and Social History Review* (Delhi) 14:11-45.
- Taube, Karl  
1992 *Major Gods of Ancient Yucatan*. Studies in Pre-Columbian Art and Archaeology No. 32. Dumbarton Oaks, Washington, D. C.
- 1998 The Jade Hearth: Centrality, Rulership, and the Classic Maya Temple. In *Function and Meaning in Classic Maya Architecture*, edited by S. D. Houston, pp. 427-478. Dumbarton Oaks, Washington, D. C.
- Thompson, J. Eric  
1939 *Excavations at San Jose, British Honduras*. Carnegie Institution of Washington Publication No. 506. Carnegie Institution, Washington, D. C.